

# 316095

# P85FIE9

## PENTOLA ELETTRICA INDIRETTA 150LT

## 150LT ELECTRIC BOILING PAN WITH INDIRECT HEATING

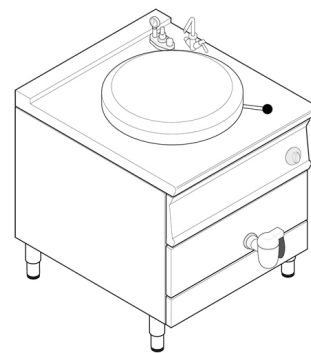

### CARATTERISTICHE TECNICHE

- \* Costruito in acciaio inox
- \* Piano di spessore 2 mm in acciaio inox AISI 304
- \* Dotata di piedi regolabili, può essere disposta a parete o ad isola
- \* Vasche di cottura in acciaio AISI 316 con spessore da 2 a 4 mm
- \* Coperchio in acciaio inox incernierato e bilanciato a molla in tutte le posizioni di apertura
- \* Sistema di riscaldamento indiretto con intercapedine d'acqua o circolazione vapore
- \* Pressione intercapedine controllata da valvola di sicurezza tarata a 0,5 bar e manometro a lettura analogica della pressione
- \* Selettore a tre posizioni e termostato di lavoro per la regolazione della temperatura
- \* Resistenze corazzate Incoloy 800

### TECHNICAL SPECIFICATIONS

- \* Made of stainless steel
- \* 2-mm-thick top
- \* Equipped with adjustable feet. It can be positioned by the wall or combined with other appliances as a central island.
- \* AISI316 steel boiling tanks with 2 to 4 mm thickness
- \* Stainless steel lid hinged and spring-balanced in all opening positions
- \* Indirect heating system with water cavity or steam circulation
- \* Cavity pressure controlled by safety valve calibrated at 0.5 bar and pressure gauge with analogue reading
- \* Three-position switch and work thermostat for temperature adjustment
- \* Heating elements shielded with Incoloy 800



Information shown is provided only as a guide. The company reserves the right to modify these data without notifying anytime. La validità dei dati riportati è indicativa. L'Azienda si riserva il diritto di apportare, in qualsiasi momento, variazioni anche senza preavviso.

**316095****P85FIE9**

PENTOLA ELETTRICA INDIRETTA 150LT

150LT ELECTRIC BOILING PAN WITH INDIRECT HEATING

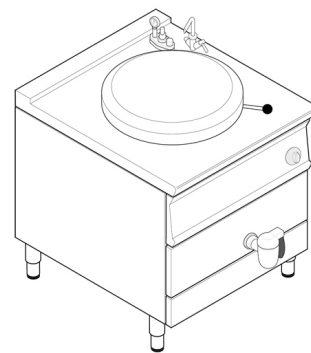
**DATI TECNICI / TECHNICAL SHEET**

Potenza / Power	kW	18
Frequenza / Frequency	Hz	50-60
Tensione / Voltage	V	400 3N ~
Capacità Vasca / Tank Capacity		150lt
Dimensione Vasca / Tank Dimensions	cm	Ø60xh54
Riscaldamento / Heating		Indiretto
Tipo Vasca / Tank Type		AISI 316
Larghezza / Width	cm	80
Profondità / Depth	cm	90
Altezza / Height	cm	90
Larghezza Imballo / Packaging Width	cm	109,0
Profondità Imballo / Packaging Depth	cm	87,0
Altezza Imballo / Packaging Height	cm	115,0
Peso Netto / Net Weight	kg	156,0000
Peso Lordo / Gross Weight	kg	178,0000
Volume / Volume	m <sup>3</sup>	01,0900



Information shown is provided only as a guide. The company reserves the right to modify these data without notifying anytime. La validità dei dati riportati è indicativa. L'Azienda si riserva il diritto di apportare, in qualsiasi momento, variazioni anche senza preavviso.